

B - B

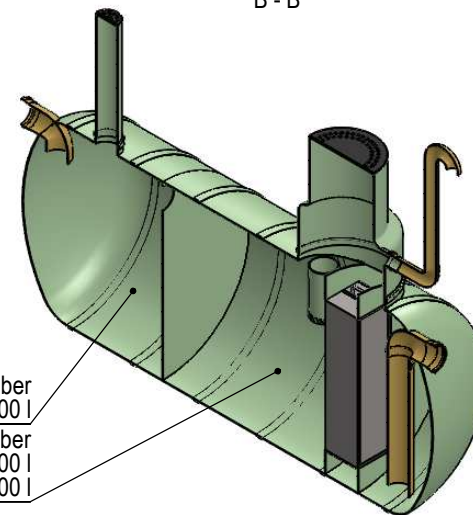

Sand and mud trap chamber  
sediment capacity 2000 l  
Oil trap chamber  
oil layer volume 300 l  
useful volume 2700 l



Separator max. flow: 20 l/s

h = inlet distance from ground (default 1500):

Item	Part	Description	Std. qty.	Need
1	Separator housing	fiberglass, $\varnothing$ 1600 x 3800	1	
2	Inlet/outlet sewer	DN200	2	
3	Maintenance shaft	$\varnothing$ 800/600	1	
4	Sediment removal shaft	$\varnothing$ 200	1	
5	Oil removal shaft	$\varnothing$ 200	1	
6	Ventilation outlet	DN110	1	
7	Coalescer block		1	
8	Level alarm device		1	
9	Separation wall		1	
10	Top cover	plastic	1	
		cast iron		

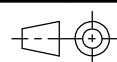

Weight

Date

6.04.2021

Drawn by E. Väljaots

Drawing no. KPK.20.01



**Klaasplast OÜ**  
reg.kood: 11862070  
tel: +372 5691 1914  
info@mahuti.ee  
www.mahuti.ee

Title

I-class oil separator with a sludge trap

Sheet  
1/1

Scale  
1 : 30

Article no.

NS20 LM2000